

3232 Series Assembly Specifications

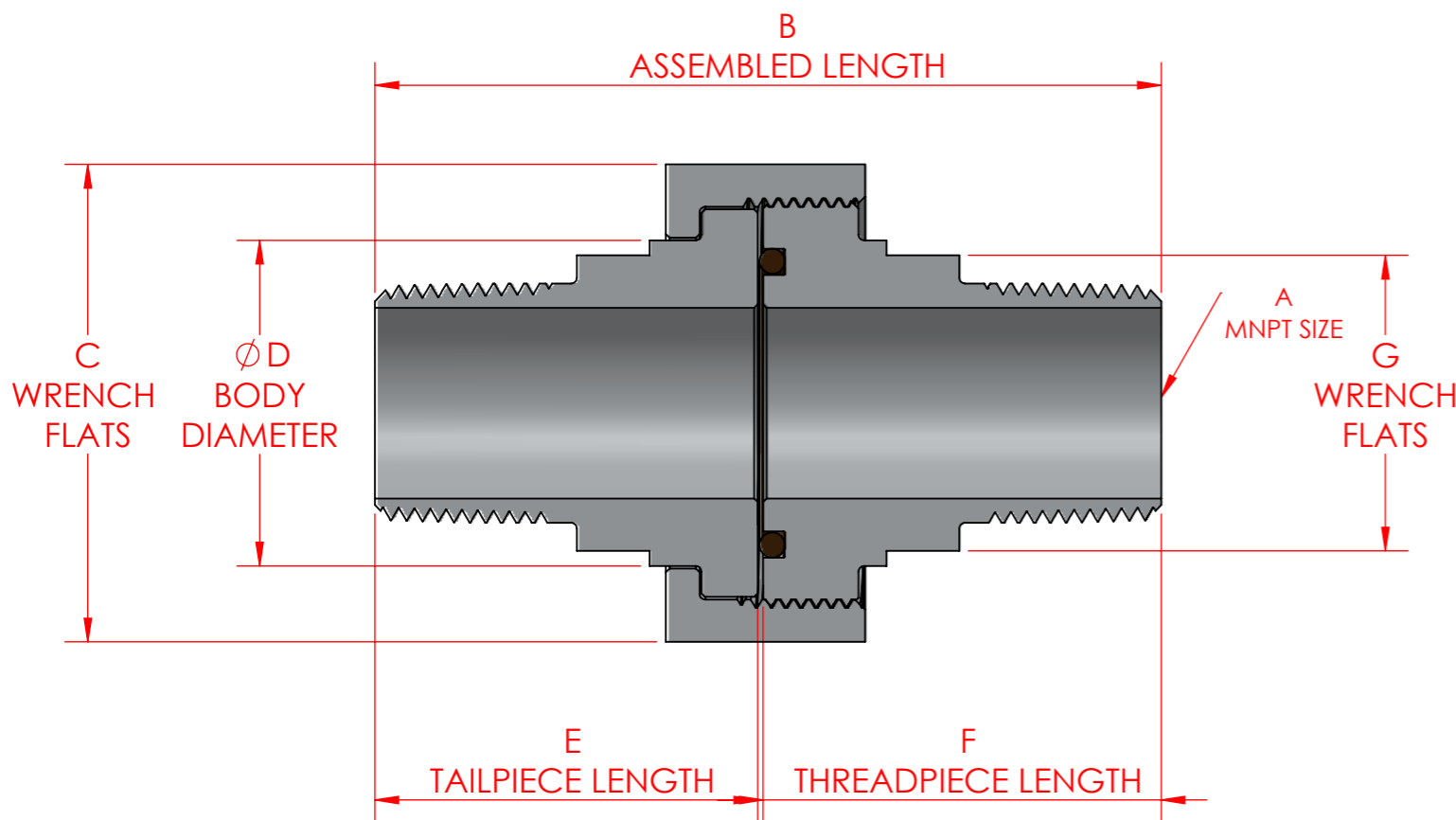

HART Size	A (MNPT Size)	B (Assembled)	C (Hex Nut Flats)	D (Body Diameter)	E (Tail)	F (Thread)	G (Wrench Flats)	Weight
3232-1	1/4" MNPT	3.130	1.375	.750	1.515	1.615	.625	.400
3232-2	3/8" MNPT	3.520	1.815	1.125	1.720	1.800	1.000	.500
3232-3	1/2" MNPT	3.720	1.815	1.125	1.820	1.900	1.000	.800
3232-4	3/4" MNPT	3.820	2.145	1.375	1.870	1.950	1.150	1.250
3232-5	1" MNPT	4.230	2.500	1.750	2.060	2.170	1.500	2.000
3232-6	1 1/4" MNPT	4.510	3.062	2.160	2.250	2.260	1.875	2.900
3232-7	1 1/2" MNPT	4.440	3.375	2.375	2.190	2.250	2.125	3.800
3232-8	2" MNPT	4.630	3.875	2.875	2.220	2.410	2.560	5.000
3232-9	2 1/2" MNPT	5.990	5.000	3.610	2.980	3.010	3.250	7.000
3232-10	3" MNPT	6.180	5.500	4.300	3.090	3.090	4.000	9.500

UNLESS SPECIFIED OTHERWISE, ALL DIMENSIONS ARE IN INCHES

DIMENSIONS FOR REFERENCE ONLY AND ARE SUBJECT TO CHANGE WITHOUT NOTICE

ASSEMBLED LENGTH IS A COMPRESSED DIMENSION AND MAY VARY BASED ON O-RING COMPRESSION

DRAWING NOT TO SCALE

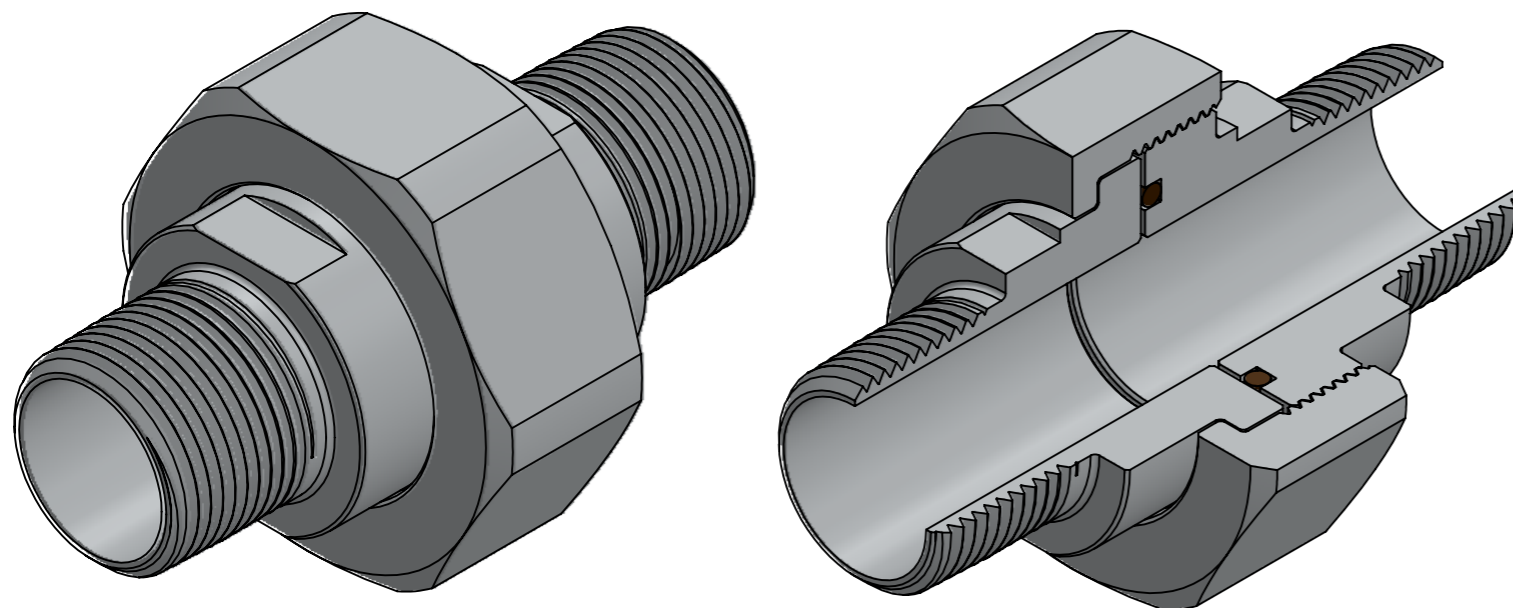

UNLESS SPECIFIED OTHERWISE, ALL DIMENSIONS ARE IN INCHES TOLERANCE: .XXX ± .005	DRAWN HWP	2-10-14	HART Industrial Unions, LLC P.O. Box 310429 Newington, CT 06131  <i>Sure Seal O-Ring Unions</i>
	CHECK SRT	2-10-14	
MATERIAL STAINLESS STEEL	REVISED BTC	2-23-23	TITLE: <h2>3232 Series Assembly Specs</h2>
COATING	CUSTOMER		
SCALE: NTS			SHEET 1 OF 1