



3000 lb. Socket Weld Union

Figure 3333 Technical Data Sheet



Product Description:

Hart Industrial O-ring Unions are engineered to provide 3000 lb. service and are the most popular union in the industry for general purpose applications. The flat face design provides turbulence free fit across seats. This design is ideal where piping requirements dictate the necessity of having a flat face seal to make and break the pipe line. Sockets are deep counter-bored for perfect alignment on pipe ends. Schedule 40 & 80 are standard but can be custom ordered to meet any schedule size. All HART Unions are made in the USA.

Standard O-Ring Union Features:

- **Turbulence Free:** All unions provide a turbulence-free fit across the seats
- **O-Ring Isolation:** The O-Ring seal is strategically located in the thread piece face reducing O-Ring media contact and added protection against abrasives and erosion.
- **Precision Machined components:** All unions are precision machined to provide high quality and fail-safe leak proof reliability.
- **Interchangeable End Connections:** Threaded, socket weld, and butt-weld ends are interchangeable. This feature reduces overall costs by eliminating unnecessary nipples, bushings, couplings and inserts.
- **Material Versatility:** Unions can be provided in all standard metals or combination of metals. This includes 304 Stainless, 316 Stainless, A 105 Carbon Steel, Brass, Monel 400, Hastalloy, and Titanium.
- **Excellent vibration resistance:** Seals will not loosen, even under extreme pressure and pressure surges.

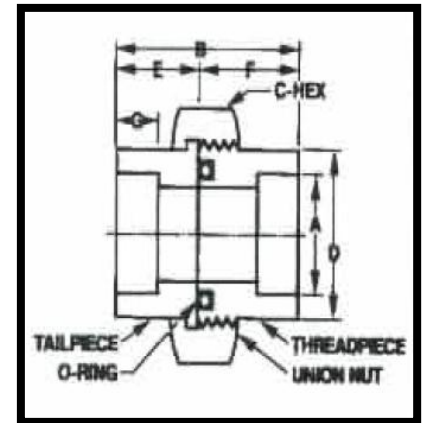

3333 Union Dimensional Reference:

FIGURE NO	A NPS	B	C HEX	D	E TAIL-PIECE	F THREAD-PIECE	G	WGT. LBS.
3333-0	1/8"	1.660	1 3/8	3/4	.785	.875	3/8	1/2
3333-1	1/4"	1.660	1 3/8	3/4	.785	.875	3/8	1/2
3333-2	3/8"	1.800	1 1/2	7/8	.863	.937	7/16	1/2
3333-3	1/2"	2.035	1 7/8	1 1/8	.935	1.100	1/2	1
3333-4	3/4"	2.148	2 1/8	1 3/8	1.023	1.125	9/16	1 1/4
3333-5	1"	2.570	2 1/2	1 3/4	1.258	1.312	5/8	2
3333-6	1 1/4"	2.822	3	2 1/8	1.385	1.437	11/16	3
3333-7	1 1/2"	3.072	3 3/8	2 3/8	1.510	1.562	3/4	4
3333-8	2"	3.259	3 7/8	2 7/8	1.572	1.687	7/8	5
3333-9	2 1/2"	3.635	4 7/8	3 1/2	1.760	1.875	7/8	8 1/2
3333-10	3"	4.135	5 1/2	4	2.010	2.125	1	9

HART INDUSTRIAL UNIONS.
P O Box 310429
Newington, CT 06131-0429

Telephone: 1-800-769-0503
Fax: 1-800-769-0504

Website: www.hartindustries.com
E-mail: info@hartindustries.com

3000 lb. Socket Weld Union

Figure 3333 Technical Data Sheet

3333 Union Component List	
1	Union Nut
2	Tailpiece
3	O-Ring
4	Threadpiece

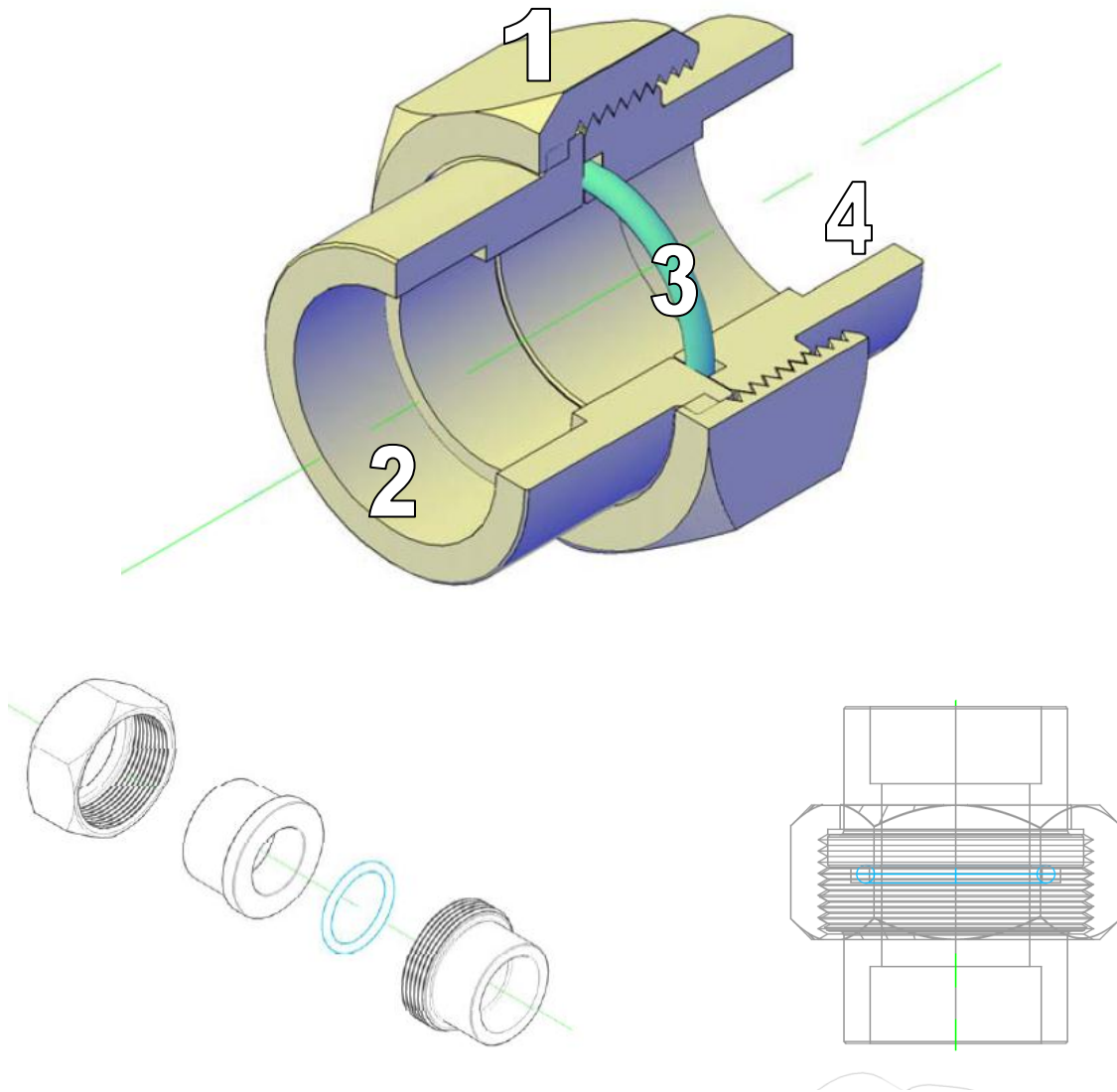

How to Order ©:

Ordering Hart specialty o-rings can be easily accomplished by visiting www.hartindustries.com. Refer to the "How to Order" link on the home page and follow the instructions outlined.

HART INDUSTRIAL UNIONS.
P O Box 310429
Newington, CT 06131-0429

Telephone: 1-800-769-0503
Fax: 1-800-769-0504
Website: www.hartindustries.com
E-mail: info@hartindustries.com