



# 6000 lb. Female Threaded FNPT Union

## Technical Data Sheet



### Product Description:

Hart Industrial O-ring Unions are engineered to provide 6000 lb. service and are the most popular union in the industry for high pressure sealing applications. The flat face design provides turbulence free fit across seats. This design is ideal where piping requirements dictate the necessity of having a flat face seal to make and break the pipe line. All HART Unions are made in the USA.

### Standard O-Ring Union Features:

- **Turbulence Free:** All unions provide a turbulence-free fit across the seats
- **O-Ring Isolation:** The O-Ring seal is strategically located in the thread piece face eliminating O-Ring media contact and added protection against abrasives and erosion.
- **Precision Machined components:** All unions are precision machined to provide high quality and fail-safe leak proof reliability.
- **Interchangeable End Connections:** Threaded, socket weld, and butt-weld ends are interchangeable. This feature reduces overall costs by eliminating unnecessary nipples, bushings, couplings and inserts.
- **Material Versatility:** Unions can be provided in all standard metals or combination of metals. This includes 304 Stainless, 316 Stainless, A 105 Carbon Steel, Brass, Monel 400, Hastalloy, and Titanium.
- **Excellent vibration resistance:** Seals will not loosen, even under extreme pressure and pressure surges.
- **No maintenance:** Once initial seal is made, no further tightening required.

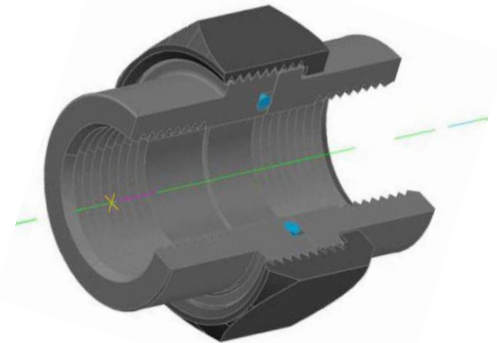
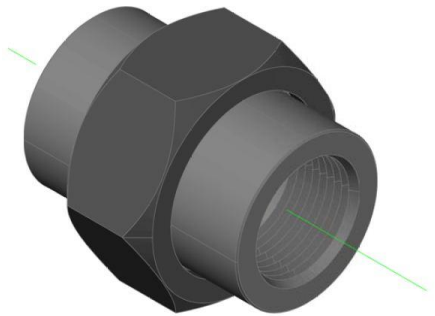

### DIMENSIONS

| FIGURE NO | A FNPT        | B     | C HEX | D     | E TAIL-PIECE | F THREAD PIECE | WGT (LBS) |
|-----------|---------------|-------|-------|-------|--------------|----------------|-----------|
| 6161-0    | 1/8"-27       | 1.660 | 1-3/8 | 3/4   | .785         | .875           | 1/2       |
| 6161-1    | 1/4"-18       | 1.800 | 1 1/2 | 7/8   | .863         | .937           | 1/2       |
| 6161-2    | 3/8"-18       | 2.035 | 1-7/8 | 1-1/8 | .935         | 1.100          | 1         |
| 6161-3    | 1/2"-14       | 2.148 | 2-1/8 | 1-3/8 | 1.023        | 1.125          | 1 1/4     |
| 6161-4    | 3/4"-14       | 2.570 | 2 1/2 | 1-3/4 | 1.258        | 1.312          | 2         |
| 6161-5    | 1"-11 1/2     | 2.822 | 3     | 2-1/8 | 1.385        | 1.437          | 3         |
| 6161-6    | 1 1/4"-11 1/2 | 3.072 | 3-3/8 | 2-3/8 | 1.510        | 1.562          | 4         |
| 6161-7    | 1 1/2"-11 1/2 | 3.259 | 3-7/8 | 2-7/8 | 1.572        | 1.687          | 5         |
| 6161-8    | 2"-11 1/2     | 3.635 | 4-7/8 | 3-1/2 | 1.760        | 1.875          | 8 1/2     |
| 6161-9    | 2 1/2"-8      | 4.135 | 5-1/2 | 4     | 2.010        | 2.125          | 9         |
| 6161-10   | 3"-8          | 4.875 | 6-7/8 | 5     | 2.375        | 2.500          | 15        |

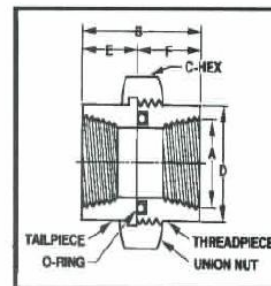

HART INDUSTRIAL UNIONS.  
P O Box 310429  
Newington, CT 06131

Telephone: 1-800-769-0503  
Fax: 1-800-769-0504

Website: [www.hartindustries.com](http://www.hartindustries.com)  
E-mail: [info@hartindustries.com](mailto:info@hartindustries.com)

# 6000 lb. Female Threaded FNPT Union

## *Technical Data Sheet*

| 6161 Union Component List |             |
|---------------------------|-------------|
| 1                         | Union Nut   |
| 2                         | Tailpiece   |
| 3                         | O-Ring      |
| 4                         | Threadpiece |

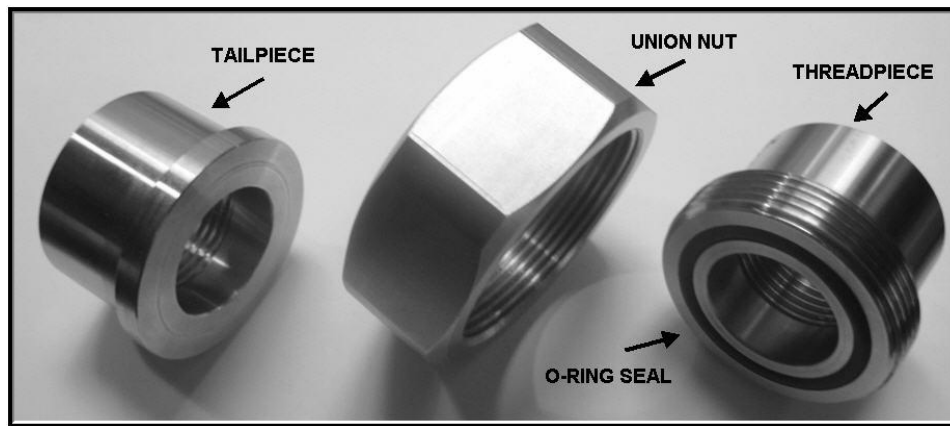
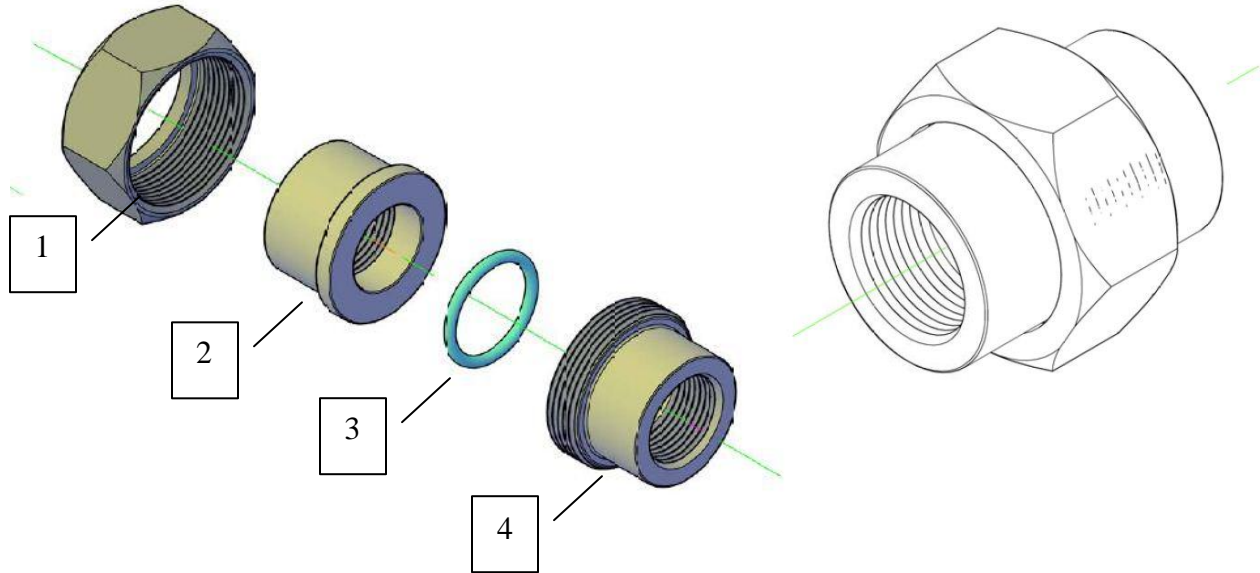

### How to Order ©:

Ordering Hart specialty o-rings can be easily accomplished by visiting [www.hartindustries.com](http://www.hartindustries.com). Refer to the "How to Order" link on the home page and follow the instructions outlined.

HART INDUSTRIAL UNIONS.  
P O Box 310429  
Newington, CT 06131

Telephone: 1-800-769-0503  
Fax: 1-800-769-0504  
Website: [www.hartindustries.com](http://www.hartindustries.com)  
E-mail: [info@hartindustries.com](mailto:info@hartindustries.com)